

BINZEL® **ABIPLAS CUT 110®**

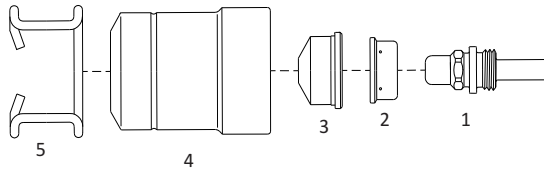

No.	Ref.	Code	Description	No.	Ref.	Code	Description
1	745.D008	52665	Electrode	3	745.D017	51540.14	Tip ø 1.4
2	745.D113	60201	Swirl ring		745.D065	51540.16	Tip ø 1.6
3	745.D018	51540.10	Tip ø 1.0	4	745.D026	60473	Shield cap
	745.D010	51540.12	Tip ø 1.2	5	745.D012	51910	Spacer spring

BINZEL® **ABIPLAS CUT 150®**

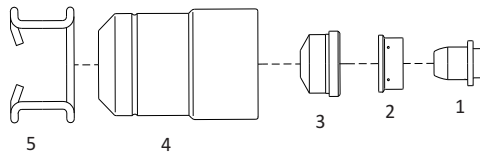

No.	Ref.	Code	Description	No.	Ref.	Code	Description
1	757.D008	52670	Electrode	3	757.D010	51550.16	Tip ø 1.6
2	757.D060	60202	Swirl ring		757.D011	51550.18	Tip ø 1.8
3	757.D037	51550.12	Tip ø 1.2	4	757.D042	60475	Shield cap
	757.D009	51550.15	Tip ø 1.5	5	757.D012	51910	Spacer spring

CEBORA® **CP-40®**

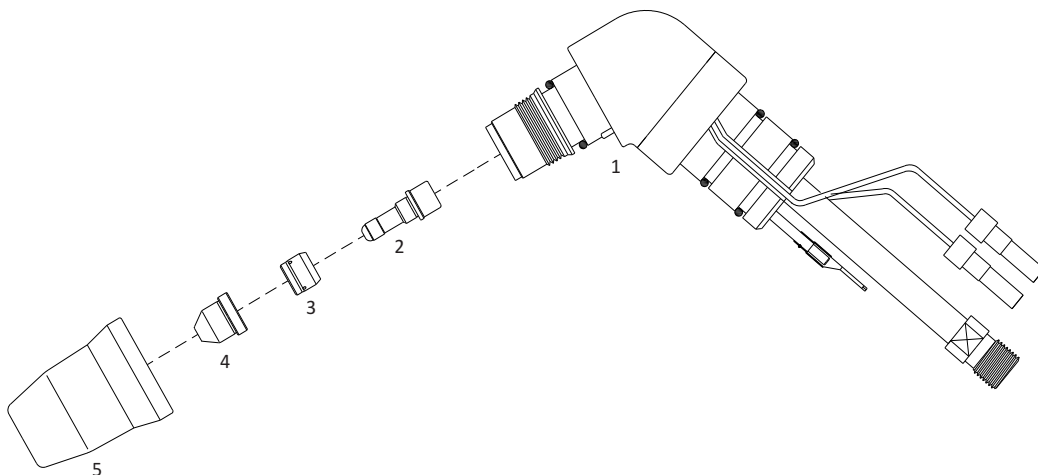

No.	Ref.	Code	Description	No.	Ref.	Code	Description
1	1359	01040	Hand torch head	4	1290	51086	Tip ø 0.7
2	1516	52545	Electrode	5	1906	60323	Retaining cap
3	1507	60007	Swirl ring				

CEBORA®

P50® - Art. 937

P35 HF® - Art. 896

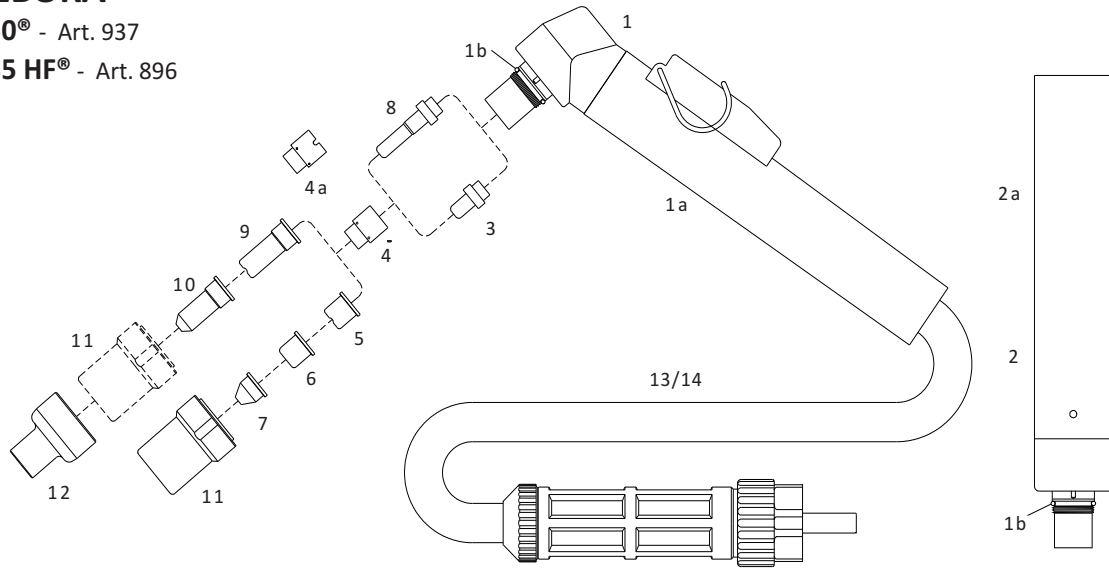

No.	Ref.	Code	Description	No.	Ref.	Code	Description	
	1526	03050/C	Hand torch, 6m, 1/8" connection	5	1396	51095	Tip Long Life ϕ 1.0	
	1574	03051/C	Hand torch, 6m, central connector			51100/S	Tip Long Life ϕ 1.1	
		03150/C	Hand torch, 12m, 1/8" connection	6		51099	Flat tip ϕ 1.0	
		03151/C	Hand torch, 12m, central connector	7	1305	51098	Conical tip ϕ 1.0 Low Amp.	
		03400	Machine torch, 6m, 1/8" connection	8	1518	52513/L	Extended electrode	
		03401	Machine torch, 6m, central connector	9	1370	51102	Extended tip ϕ 1.0	
		03500	Machine torch, 12m, 1/8" connection			1395	51095/L	Extended tip Long Life ϕ 1.0
		03501	Machine torch, 12m, central connector				51102/S	Extended tip Long Life ϕ 1.1
1	1352	01000	Hand torch head	10	1306	51101	Extended conical tip ϕ 1.0	
1a	1356	03280/C	Handgrip with microswitch				Low Amperage	
1b		01000.60	O-Ring	11	5.710.121	60320	Retaining cap	
2		03300	Machine torch head	12		51965	Shield cap, hand, extended tips	
2a		03310	Machine handle	13	1344	03240	Cable, 6m, 1/8", Hand torch	
3	1521	52512/L	Electrode			03250	Cable, 12m, 1/8", Hand torch	
4		60001	Swirl ring	14		03320	Cable, 6m, 1/8", Machine torch	
4a	1510	60002	Swirl ring with notches			03330	Cable, 12m, 1/8", Machine torch	
5	1304	51100	Tip ϕ 1.0					

LT-50®

Suitable for
CEBORA® P50®

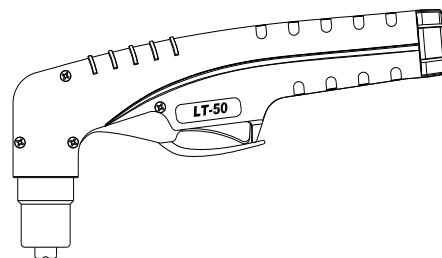

Consumables:
see CEBORA® P50®

Ref.	Code	Description	Ref.	Code	Description
1526	03050LT	Hand torch, 6m, 1/8" connection		01001	Torch head
1574	03051LT	Hand torch, 6m, central connector		01000.60	O-Ring
	03150LT	Hand torch, 12m, 1/8" connection		09606	Handgrip with switch
	03151LT	Hand torch, 12m, central connector		07301.20	Switch
	01001/Kit	Torch head with handle			

CEBORA®

P70® - Art. 941
35 PC/HF® - Art. 292
P36® - Art. 938
P52® - Art. 940

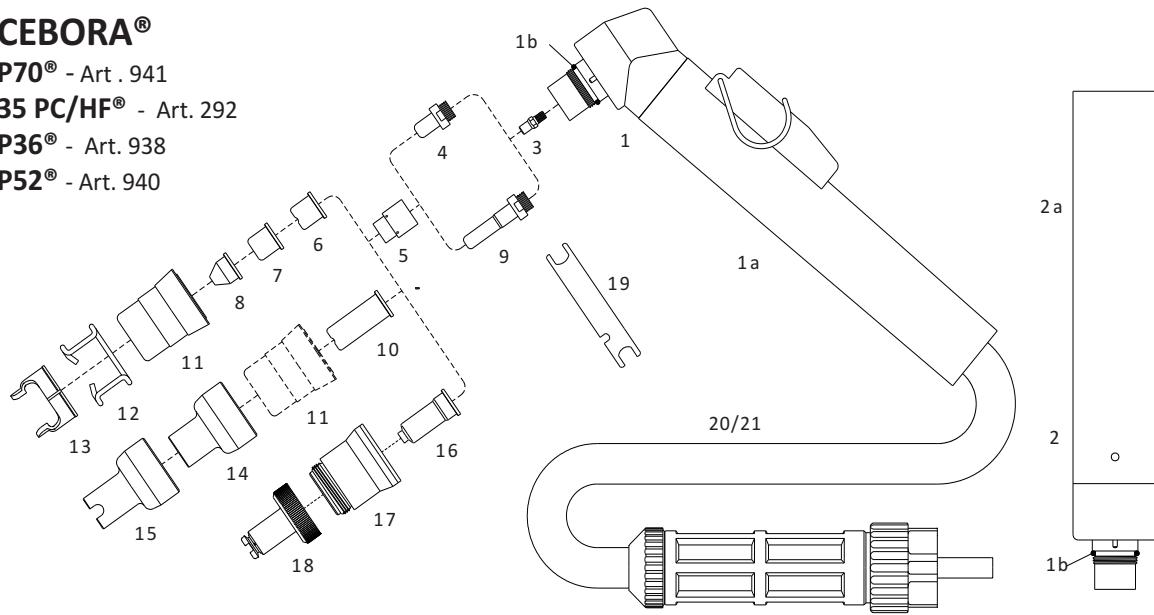

No.	Ref.	Code	Description	No.	Ref.	Code	Description
1564		03070/CS	Hand torch, 6m, 1/8" connection	8		51098.12	Conical tip ϕ 1.2
1573		03071/CS	Hand torch, 6m, central connector	9	1368	52553	Extended electrode
1573.20		03171/CS	Hand torch, 12m, central connector	10	1366	51102.09	Extended tip ϕ 0.9 35A
1563		03470/S	Machine torch, 6m, 1/8" connection	1395		51095/L	Extended tip Long Life ϕ 1.0 50A
1566		03471/S	Machine torch, 6m, central connector			51102/S	Extended tip Long Life ϕ 1.1 60A
1566.20		03571/S	Machine torch, 12m, central connector			51096/L	Extended tip Long Life ϕ 1.2 70A
1	1351	01070	Hand torch head	11	5.710.171	60321	Retaining cap
1a	1356	03280/C	Handgrip with microswitch	12	1394	51901	Spacer spring
1b	3.160.067	01000.60	O-Ring	13	1405	60363	Double pointed spacer
2	1349	03370	Machine torch head	14		51970	Shield cap hand 51102.09 & 51095/L
2a	3.055.623	03310	Machine handle	15		51971	Spacer, contact cutting, 51102/S & 51096/L
3	3.065.204	01070.42	Diffusor	16		51097.10	Extended tip, 50A, shielded
4	1402	52551	Electrode			51097.11	Extended tip, 60A, shielded
5		60001	Swirl ring			51097.12	Extended tip, 70A, shielded
6	1309	51100.09	Tip ϕ 0.9 35A	17		60321C	Shield cap body CW
	1396	51095	Tip Long Life ϕ 1.0 50A	18		60503L	Extended shield cap 50-70A
		51100/S	Tip Long Life ϕ 1.1 60A	19	3.045.012	60368	Wrench for electrode
		51096	Tip Long Life ϕ 1.2 70A	20	1344	03240/S	Cable, 6m, 1/8", Hand torch
7	1308	51100.12	Tip ϕ 1.2 70A			03250/S	Cable, 12m, 1/8", Hand torch
		51099	Flat tip ϕ 1.0	21		03320/S	Cable, 6m, 1/8", Machine torch
		51099.12	Flat tip ϕ 1.2			03330/S	Cable, 12m, 1/8", Machine torch
8	1305	51098	Conical tip ϕ 1.0 Low Amp.				

LT-70®

Suitable for
CEBORA® P70®

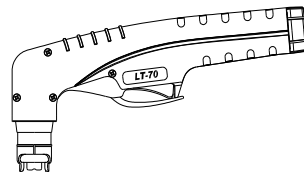

Consumables:
 see **CEBORA® P70®**

Ref.	Code	Description	Ref.	Code	Description
1564	03070LTS	Hand torch, 6m, 1/8" connection		01071	Torch head
1573	03071LTS	Hand torch, 6m, central connector		01000.60	O-Ring
	03170LTS	Hand torch, 12m, 1/8" connection		09606	Handgrip with switch
1573.20	03171LTS	Hand torch, 12m, central connector		07301.20	Switch
	01071/Kit	Torch head with handle			

CEBORA®

CP-90® - CP-91®
 PC 5060/T® - Art. 354
 PC 6060/T® - Art. 355
 PC 9060/T® - Art. 356
 P55® - Art. 965
 P80® - Art. 947

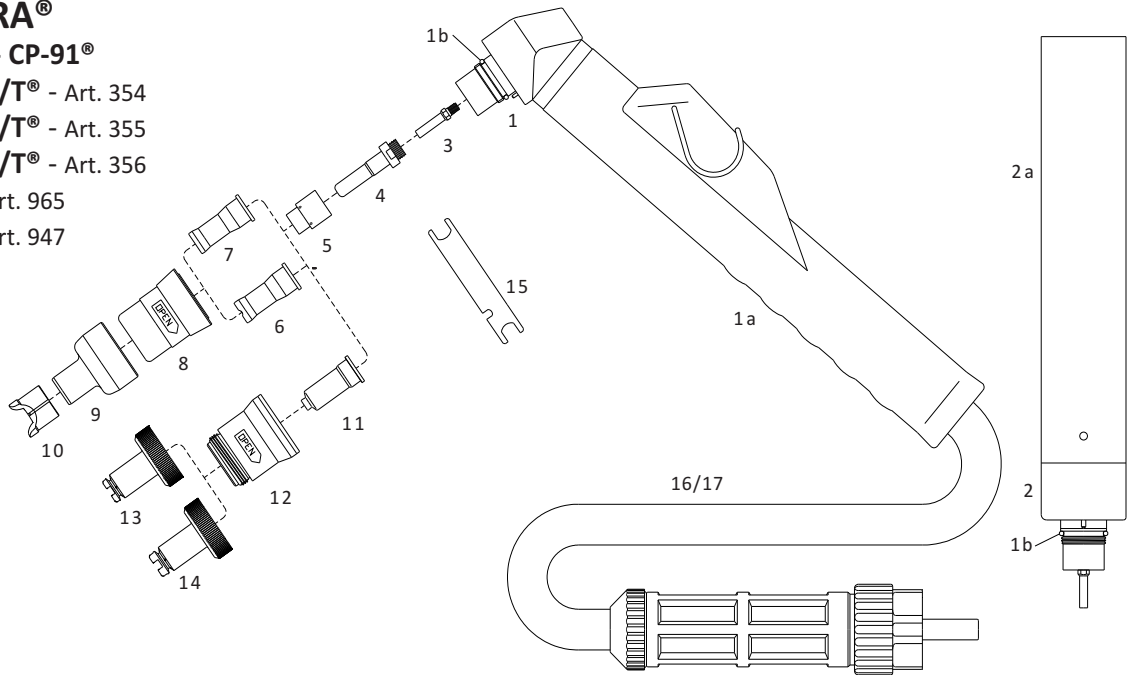

No.	Ref.	Code	Description	No.	Ref.	Code	Description
1214		03091/CS	Hand torch, 6m, central connector	10		51973	Spacer for contact cutting hand
1214.20		03191/CS	Hand torch, 12m, central connector	11		51097.10	Extended tip, 50A, shielded
1218		03491/S	Machine torch, 6m, central connector			51097.11	Extended tip, 60A, shielded
1218.20		03591/S	Machine torch, 12m, central connector			51097.12	Extended tip, 70A, shielded
1215		03090/CS	Hand torch, 6m, 1/8" connection			51097.13	Extended tip, 90-100A, shielded
1	1358	01090	Hand torch head	12		60322C	Shield cap body CCW
1a		04280/C	Handgrip with microswitch	13		60503L	Extended shield cap 50-70A
1b	3.160.067	01000.60	O-Ring	14		60504L	Extended shield cap 80-100A
2	1348	03390	Machine torch head	15	3.045.012	60368	Wrench for electrode
2a	3.055.623	03310	Machine handle	16		03093/S	Cable 6m, 1/8", hand,
3		01090.42	Diffusor			03193/S	Cable 12m, 1/8", hand,
4	1368	52553	Electrode				ready for central connector
5		60001	Swirl Ring			17	Cable 6m, 1/8", machine,
6		51090	Tip Long Life ø 1.0 - 20-50A item 8 only				ready for central connector
7		51092	Tip Long Life ø 1.2 - 50-70A item 8 only			03493/S	Cable 6m, 1/8", machine,
		51093	Tip Long Life ø 1.3 - 70-90A item 8 only				ready for central connector
8		60322	Retaining cap for item 6/7 only			03593/S	Cable 12m, 1/8", machine,
9		51972	Shield cap hand				ready for central connector
						03240/S	Cable 6m, 1/8", hand

LT-90®

Suitable for
 CEBORA® CP-90® CP-91®

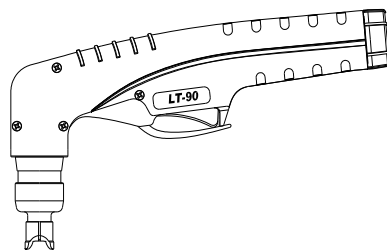

Consumables:
 see CEBORA® CP-90® CP-91®

Ref.	Code	Description	Ref.	Code	Description
1215	03090LTS	Hand torch, 6m, 1/8" connection	01091		Torch head
1214	03091LTS	Hand torch, 6m, central connector	01000.60		O-Ring
1214.20	03191LTS	Hand torch, 12m, central connector	09606		Handgrip with switch
	01091/Kit	Torch head with handle	07301.20		Switch

CEBORA®

P150® - CP-160®

- P90®** Art. 942
- P92®** Art. 943
- P120®** Art. 945
- P122®** Art. 946
- P150®** Art. 950
- P152®** Art. 951
- P162®** Art. 952

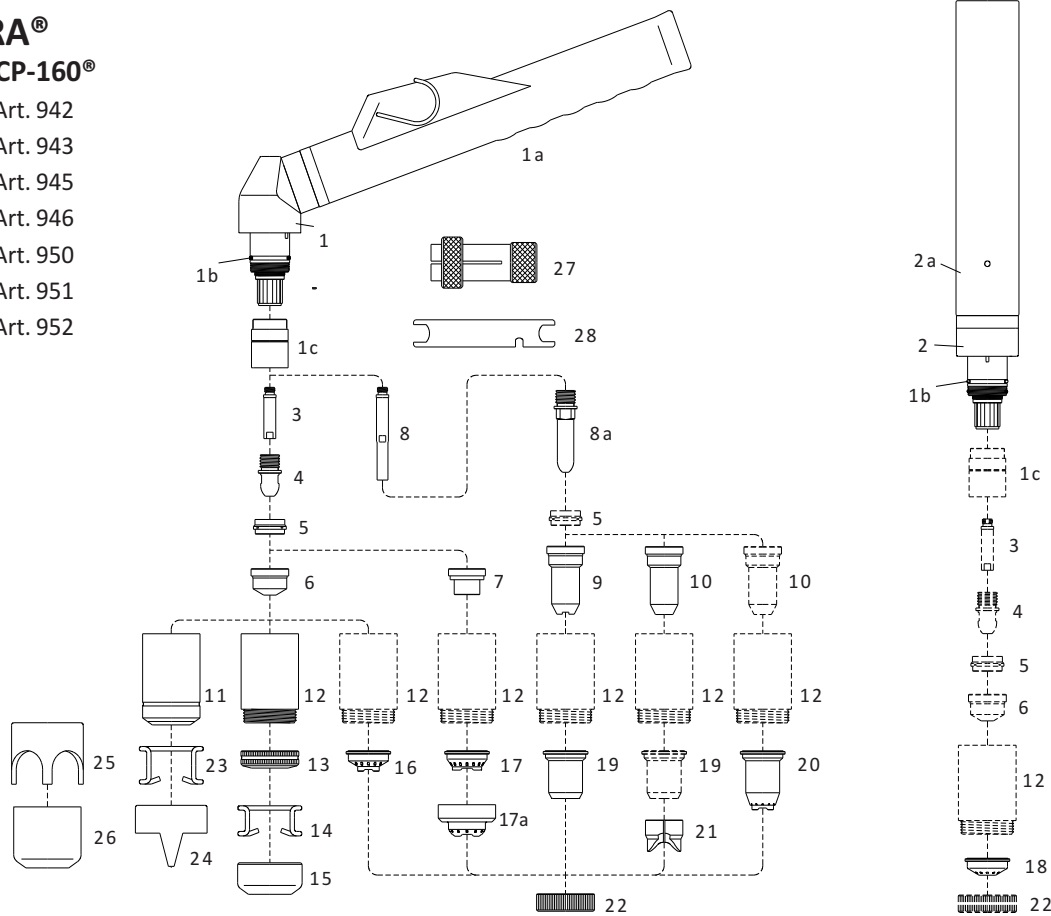

No.	Ref.	Code	Description	No.	Ref.	Code	Description
CP-160®				8a	1517	52549	Extended electrode
1226		04053/CS	Hand torch, 6m, central connector	9	1369	51148	Contact extended tip max 50A
1226.20		04153/CS	Hand torch, 12m, central connector	10		51148.13	Extended tip ø 1.35 - 90A
1228		08679	Machine torch, 6m shielded, central conn.			51148.16	Extended tip ø 1.6 - 120A
1228.20		08685	Machine torch, 12m shielded, central conn.			51148.18	Extended tip ø 1.8 - 150A
P-150®				11	1389	60330	Retaining cap
1571		04050/CS	Hand torch, 6m, 1/8" connection	12		60350	Contact retaining cap
1576		04051/CS	Hand torch, 6m, central connector			60350/V	Contact retaining cap, Max Life
1578		04151/CS	Hand torch, 12m, central connector	13		51952	Spring holder protection nut
1529		04400/S	Machine torch 6m, 1/8" connection	14		51911	Spacer spring for code 51952
1577		04401/S	Machine torch 6m, central connector	15		51953	Gouging spacer
1579		04501/S	Machine torch 12m, central connector	16		51950	Spacer for contact cutting hand
1	1353	02000	Hand torch head	17		51930	Spacer for contact cutting hand
1a		04280/C	Handgrip with microswitch	17a		51920	Spacer for contact cutting hand
1b	1398	02000.60	O-Ring	18		51951	Shield cup machine
1c		60080	Front insulator	19		51957	Shield cup hand max 50A
2	1354	04300	Machine torch head	20		51958	Spacer for contact cutting hand
2a	3.055.623	03310	Machine handle	21		51974	Spacer for extended tips High Amp.
3		1378	05004 Diffusor	22		51959	Locking nut
4	1376	52540	Electrode	23	1386	51910	Spacer spring
5	1377	60020	Swirl ring	24	1408	60370	Double pointed spacer
6	1371	51140/S	Tip Long Life ø 1.1	25		60371	Crown spacer
	1372	51141/S	Tip Long Life ø 1.35	26	1406	60373	Gouging spacer
	1373	51142/S	Tip Long Life ø 1.6	27	1509	60369	Extractor for swirl ring
	1374	51143/S	Tip Long Life ø 1.8	28	3.045.010	60368	Wrench for electrode
	1375	51144	Gouging tip ø 3.0			04240/S	Cable, 6m, 1/8", Hand torch
7		51410	Contact tip ø 1.35			04250/S	Cable, 12m, 1/8", Hand torch
		51411	Contact tip ø 1.6			04320/S	Cable, 6m, 1/8", Machine torch
		51412	Contact tip ø 1.8			04330/S	Cable, 12m, 1/8", Machine torch
8		05005	Extended diffusor				