

HYPERTHERM®
POWERMAX 1000® T60/T60M®
POWERMAX 1250® T80/T80M®
POWERMAX 1650® T100/T100M®

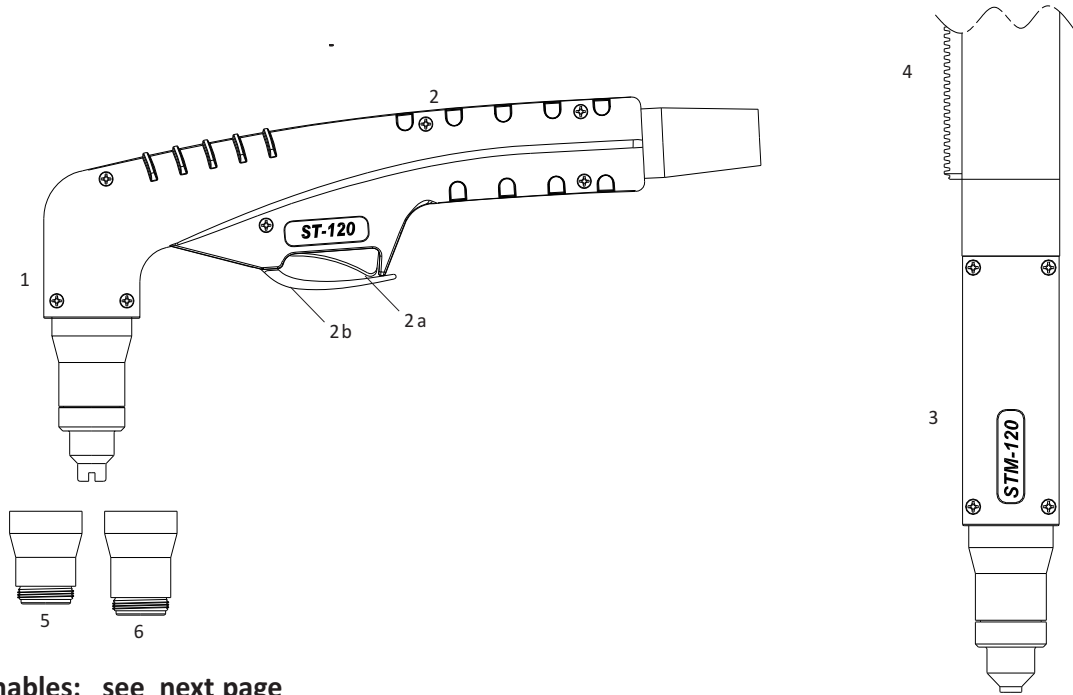
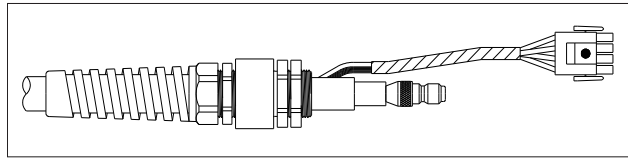

Consumables: see next page

No.	Code	Description	No.	Code	Description
1	03800	ST-120 Hand torch head		02800.60	O-Ring
2	09705	Handle with switch	4	07216	Positioning tube with rack
2a	07301.20	Switch	5	60495	Retaining cap, 40-80A
2b	09605.42	Safety tab	6	60496	Retaining cap, 100A
3	03810	STM-120 machine torch head			

Torches and leads
POWERMAX 1000® T60/T60M®
POWERMAX 1250® T80/T80M®

Code	Description	Code	Description
03820CX-HY	ST-120 Hand torch, 7.5m, 25'	03830CX-HY	STM-120 Machine torch, 7.5m, 25'
03825CX-HY	ST-120 Hand torch, 15m, 50'	03835CX-HY	STM-120 Machine torch, 15m, 50'
09781CX-HY	Lead assembly, hand, 7.5m, 25'	09791CX-HY	Lead assembly, machine, 7.5m, 25'
09786CX-HY	Lead assembly, hand, 15m, 50'	09796CX-HY	Lead assembly, machine, 15m, 50'

Torches and leads
POWERMAX 1650® T100/T100M®

Code	Description	Code	Description
03821CX-HY	ST-120 Hand torch, 7.5m, 25'	03831CX-HY	STM-120 Machine torch, 7.5m, 25'
03826CX-HY	ST-120 Hand torch, 15 m, 50'	03836CX-HY	STM-120 Machine torch, 15m, 50'
09780CX-HY	Lead assembly, hand, 7.5m, 25'	09790CX-HY	Lead assembly, machine, 7.5m, 25'
09785CX-HY	Lead assembly, hand, 15m, 50'	09795CX-HY	Lead assembly, machine, 15m, 50'

HYPERTHERM®

POWERMAX 1000® T60/T60M®
 POWERMAX 1250® T80/T80M®
 POWERMAX 1650® T100/T100M®
 POWERMAX 1100® RT80/RT80M®
 RT60/RT60M®

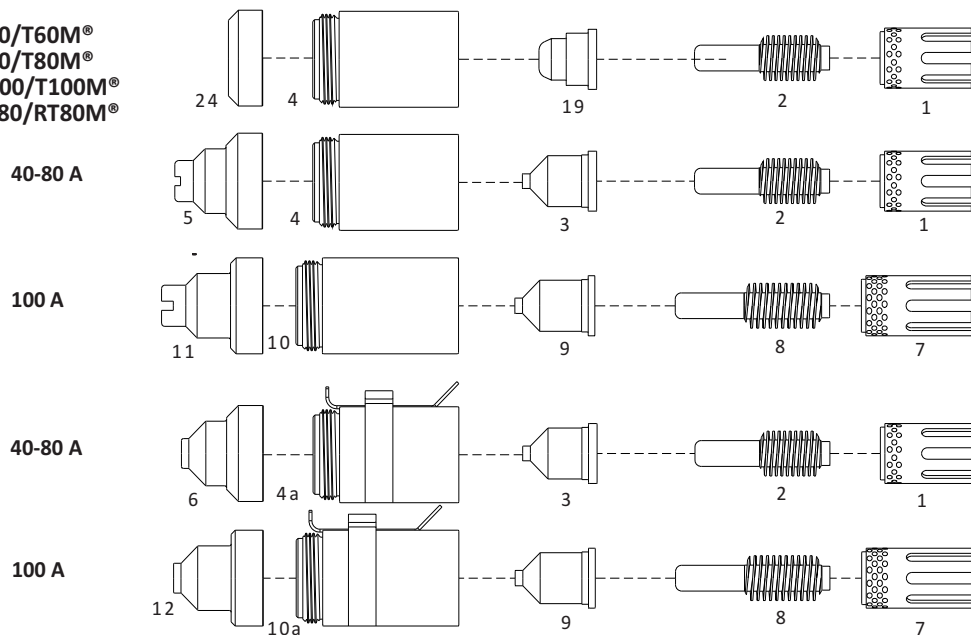

TECMO DESIGN

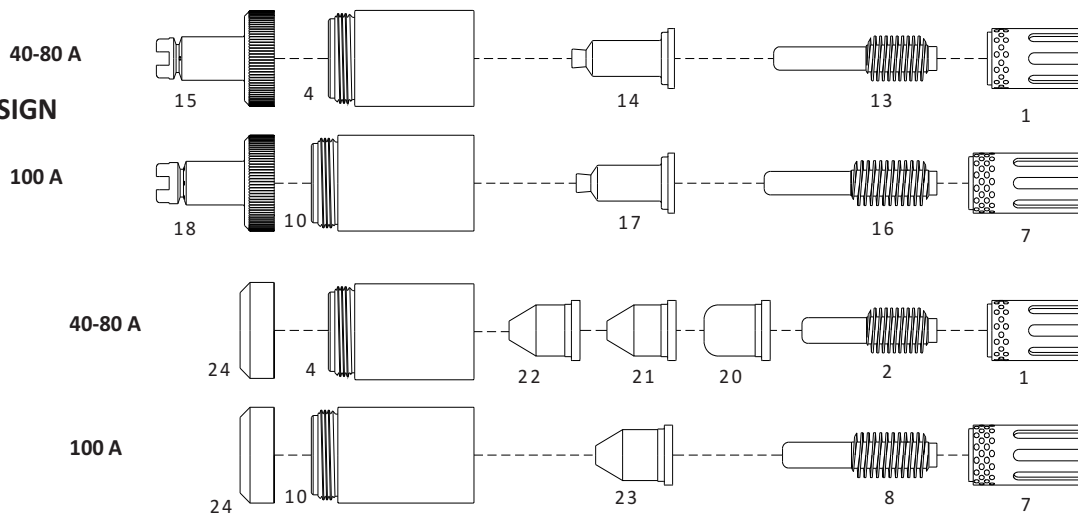

No.	Ref.	Code	Description	No.	Ref.	Code	Description
1	120925	60043	Swirl ring Max Life 40/80A	10a	220206	60307H	Retaining cap 100A OHMIC
	120925	60043E	Swirl ring 40/80A	11	220065	51983/TD	Hand shield 100A
2	120926	52675	Electrode 40-80A	12	220047	51984/TD	Machine shield 100A
	120926	52675BM	Electrode 40-80A BiMetal	13	TD	52675L	Extended electrode 40-80A
3	120932	51405.10	Tip 40A shielded	14	TD	51405L.10	Extended tip 40A shielded
	120931	51405.12	Tip 60A shielded		TD	51405L.12	Extended tip 60A shielded
	120927	51405.14	Tip 80A shielded		TD	51405L.14	Extended tip 80A shielded
4	120928	60304	Retaining cap 40/80A	15	TD	60505L	Extended shield 40-80A
4a	220061	60304H	Retaining cap 40/80A OHMIC	16	TD	52676L	Extended electrode 100A
5	120929	51981/TD	Hand shield 40/80A	17	TD	51406L.15	Extended tip 100A shielded
6	120930	51982/TD	Machine shield 40/80A	18	TD	51983L	Extended shield 100A
7	220051	60044	Swirl ring Max Life 100A	19	220329	51407	Tip 30-50A Precision Cut
	220051	60044E	Swirl ring 100A	20	220006	51402	Tip 40A unshielded
8	220037	52676	Electrode 100A	21	220007	51403	Tip 60A unshielded
	220037	52676BM	Electrode 100A BiMetal	22	120980	51404	Tip 80A unshielded
9	220011	51406	Tip 100A shielded	23	220064	51408	Tip 100A unshielded
10	220048	60307	Retaining cap 100A	24	120979	51939	Deflector

HYPERTHERM® POWERMAX 45® H45®

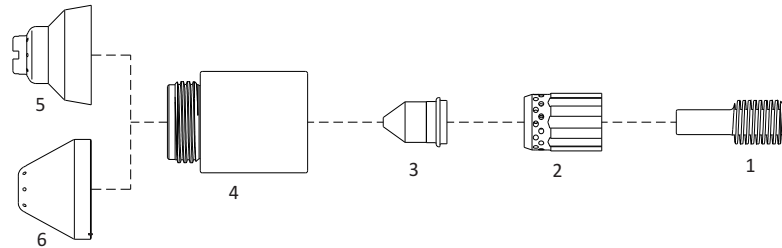

No.	Ref.	Code	Description	No.	Ref.	Code	Description
1	220669	52574	Electrode	4	220713	60305	Retaining cap
2	220670	60041	Swirl ring	5	220674	51923	Hand shield
3	220671	51206	Tip 45A	6	220673	51924	Machine shield

HYPERTHERM® POWERMAX 65® H65® M65® POWERMAX 85® H85® M85® POWERMAX 105® H105® M105®

POWERMAX 1000/1250/1650® HRT® MRT® Retrofit torch

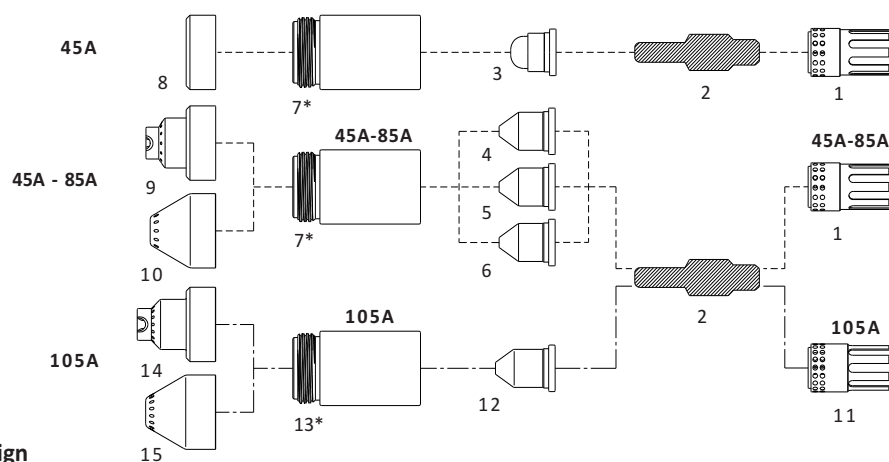

* Differ from OEM design

No.	Ref.	Code	Description	No.	Ref.	Code	Description
1	220857	60042	Swirl ring 45-85A	9	220818	51921	Hand shield 45-85A
2	220842	N/A	Electrode 45-100A	10	220817	51922	Machine shield 45-85A
3	220930	51415	Tip 45A Precision Cut	11	220994	60040	Swirl ring 105A
4	220941	51416	Tip 45A (for use with item # 7)	12	220990	51419	Tip 100A (for use with item # 13)
5	220819	51417	Tip 65A (for use with item # 7)	13*	220854/105	60309B	Retaining cap 105A
6	220816	51418	Tip 85A (for use with item # 7)	14	220992	51926	Hand shield 105A
7*	220854/85	60309A	Retaining cap 45-85A	15	220993	51927	Machine shield 105A
8	220955	51928	Deflector				

HYPERTHERM® MAX 20® PAC110®

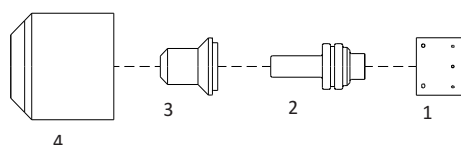

No.	Ref.	Code	Description	No.	Ref.	Code	Description
1	020239	60035	Swirl ring	3	020381	51216	Extended tip ϕ 0,73 - .029
2	020382	52571	Extended electrode	4	020218	60300	Retaining cap

HYPERTHERM®
POWERMAX 350® PAC110®
POWERMAX 380® PAC110T®

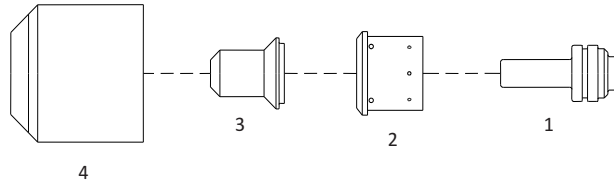

No.	Ref.	Code	Description	No.	Ref.	Code	Description
1	020382	52571	Extended electrode	3	120504	51217	Extended tip \varnothing 0,81 - .032
2	220013	60037	Swirl ring	4	220016	60300	Retaining cap

HYPERTHERM®
POWERMAX 600®
PAC123T/M®

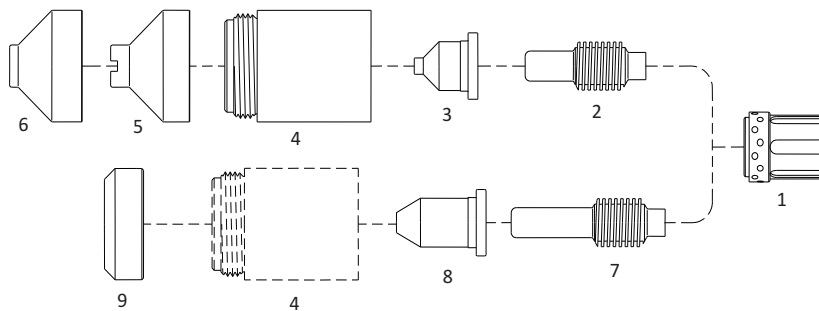

No.	Ref.	Code	Description	No.	Ref.	Code	Description
1	120576	60047	Swirl ring	6	120827	51979/TD	Machine shield
2	120573	52575	Electrode	7	120574	52576	Extended electrode
3	120826	51214	Tip 40A	8	120606	51208	Extended tip 35A
4	120600	60316	Retaining cap	9	120303	51987/TD	Deflector
5	120828	51978/TD	Hand shield				

HYPERTHERM®
POWERMAX 800®
MAX 42/43®/40CS®
PAC121PT/M®
PAC121TS/M®

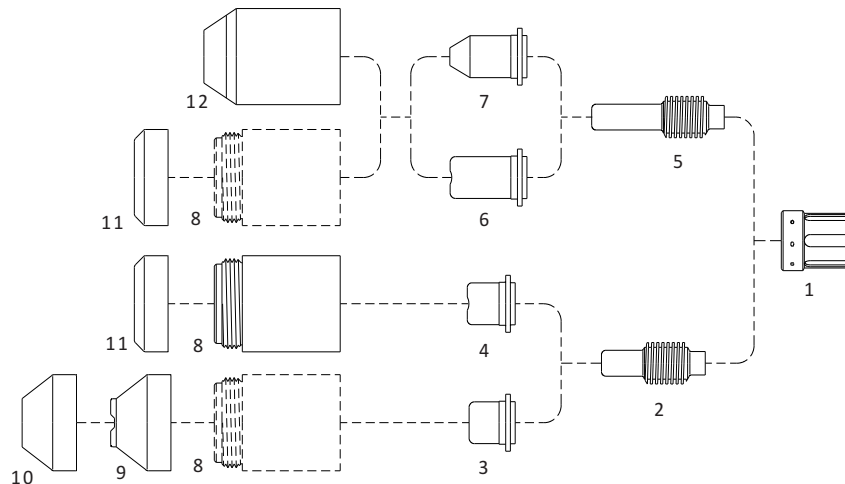

No.	Ref.	Code	Description	No.	Ref.	Code	Description
1	020361	60046	Swirl ring	7	120305	51203	Tip pipe saddle
2	120573	52575	Electrode (replaces 020351)	8	120301	60313/TD	Retaining cap
3	120438	51204	Tip 40A	9	120283	51985/TD	Hand shield
	120282	51201	Tip 50A	10	120326	51986/TD	Machine shield
4	020395	51211	Tip 50A	11	120303	51987/TD	Deflector
5	120574	52576	Extended electrode (replaces 020547)	12	020930	60303	Retaining cap
6	120304	51202	Extended tip				

HYPERTHERM® POWERMAX 900® PAC125T/M®

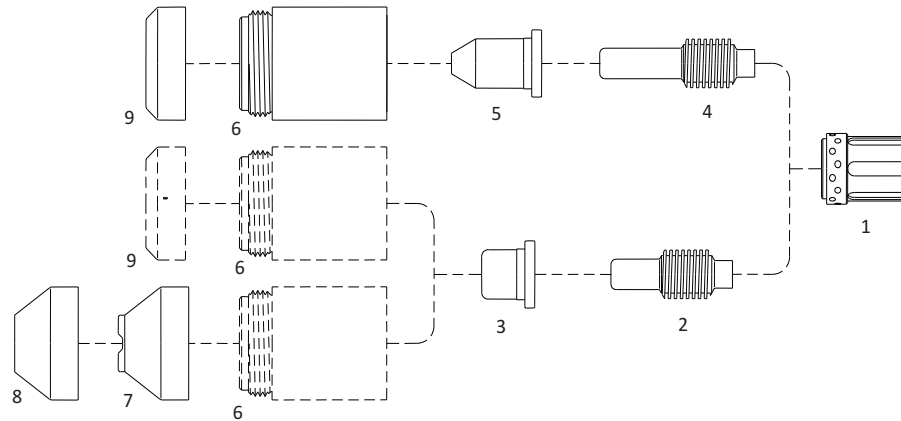

No.	Ref.	Code	Description	No.	Ref.	Code	Description
1	120576	60047	Swirl ring	120578	51209	51209	Extended tip 55A pipe saddle
2	120573	52575	Electrode	6	120600	60316	Retaining cap
3	120577	51207	Tip 55A shielded	7	120601	51985/TD	Hand shield
4	120574	52576	Extended electrode	8	120602	51986/TD	Machine shield
5	120606	51208	Extended tip 35A	9	120303	51987/TD	Deflector

HYPERTHERM® MAX 40® PAC140® HT40®

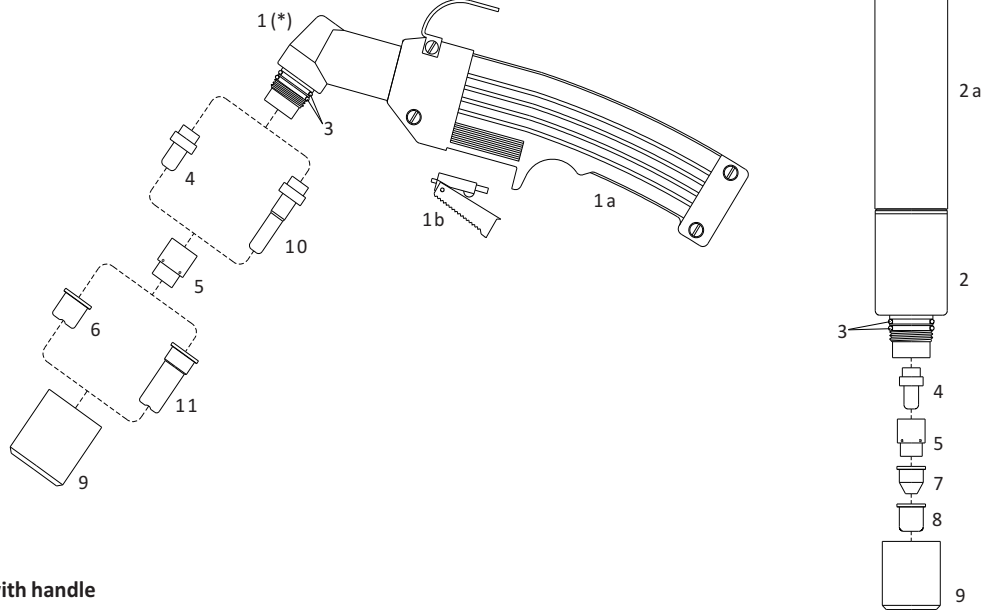

(*) complete with handle

No.	Ref.	Code	Description	No.	Ref.	Code	Description
	057112	07320	Hand torch 25'	3	026016	07300.60	O-Ring
	057113	07330	Hand torch 50'	4	020103	52512/L	Electrode
		07340	Machine torch 25'	5	020101	60001	Swirl ring
		07350	Machine torch 50'	6	020115	51100	Tip, hand torch
1	057114	07300	Hand torch body (*)	7	020131	51098	Pipe saddle tip, machine torch
1a		07301	Handgrip with switch	8	020102	51099	Tip, machine torch
1b		07301.20	Switch	9	020104	60301	Retaining cap
2	020114	07310	Machine torch body	10	020467	52513/L	Extended electrode
2a	020206	07315	Machine handle	11	020466	51102	Extended tip

HYPERTHERM® MAX 80/100® PAC130®

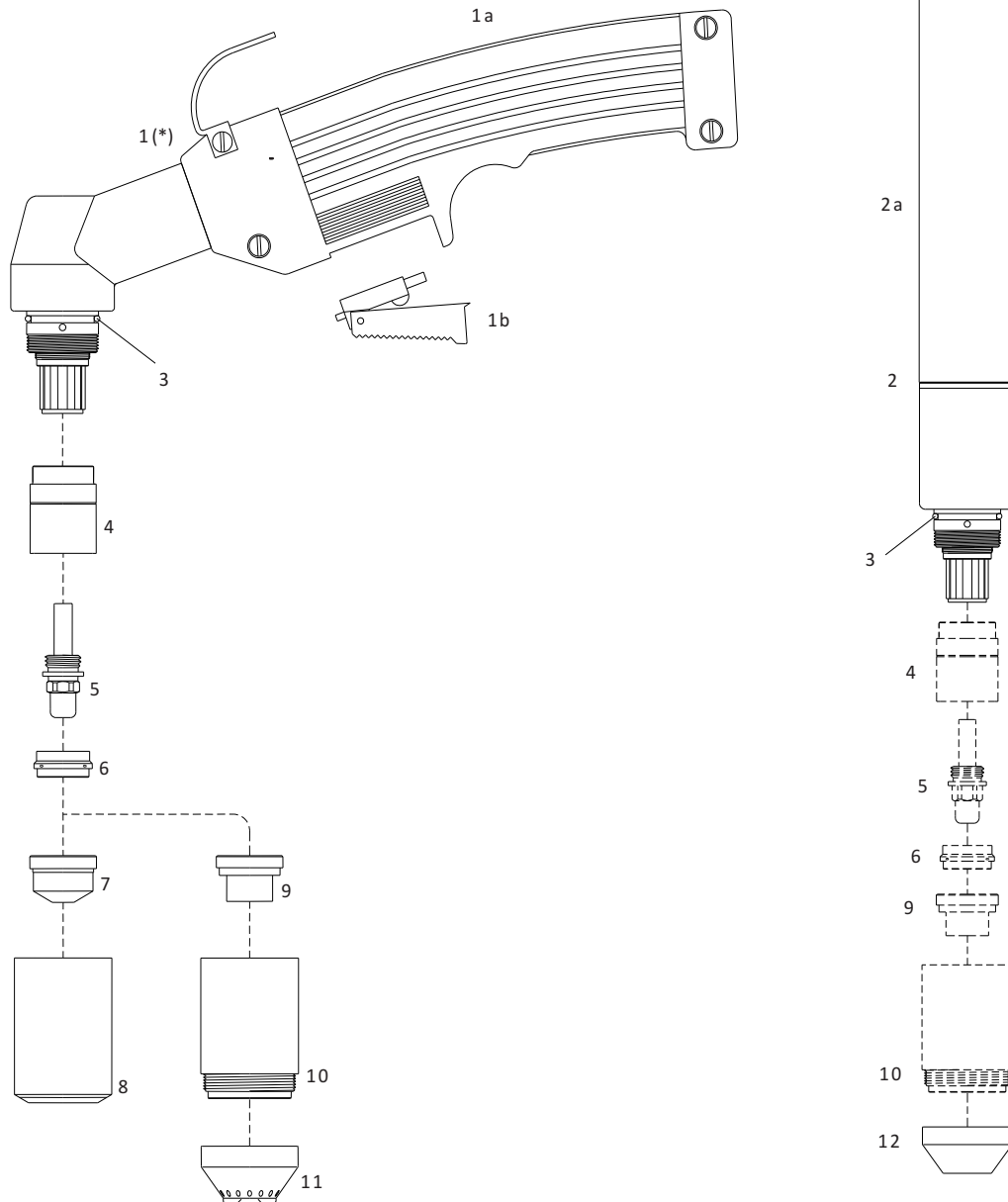

(*) complete with handle

No.	Ref.	Code	Description	No.	Ref.	Code	Description
	059076	07420	Hand torch 25'	6	020194	60010	Swirl ring
	059077	07430	Hand torch 50'	7	020203	51120	Tip 40A ϕ 1,0 - .038
		07440	Machine torch 25'		020345	51121	Tip 80A ϕ 1,3 - .052
		07450	Machine torch 50'		020195	51122	Tip 100A ϕ 1,5 - .059
1	020189	07400	Hand torch body (*)	8	020184	60310	Retaining cap
1a		07301	Handgrip with switch	9	020397	51400	Contact tip 80A ϕ 1,3 - .052
1b		07301.20	Switch		020337	51401	Contact tip 100A ϕ 1,5 - .059
2	020201	07410	Machine torch body	10		60340/TD	Contact retaining cap
2a	020245	07215	Machine handle			60340/V/TD	Contact retaining cap Max Life
3	026018	06000.60	O-ring	11	020335	51930/TD	Spacer, hand contact cutting
4		60080	Front insulator	12	020334	51935/TD	Machine shield cap
5	120433	52520/TD	Electrode (replaces 020191)				