

## TRAFIMET® A53 - S54

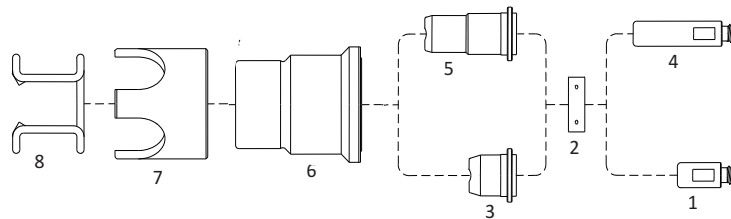

No.	Ref.	Code	Description	No.	Ref.	Code	Description
1	PR105	52536	Electrode		PD103	51317	Extended tip $\varnothing$ 1.0
2	PE106	60028	Swirl ring	6	PC115	60384	Retaining cap for S54
3	PD102-10	51315	Tip $\varnothing$ 1.0	7	CV33	60378	Crown spacer
4	PR106	52532	Extended electrode	8	CV28	51902	Spacer spring
5	PD103-09	51317.09	Extended tip $\varnothing$ 0.9				

## TRAFIMET® A60

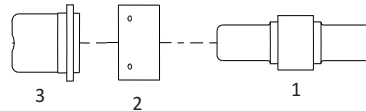

No.	Ref.	Code	Description	No.	Ref.	Code	Description
1	PR107	52537	Electrode	3	PD105.10	51170	Tip $\varnothing$ 1.0
2	PE107	60029	Swirl ring		PD105.11	51172	Tip $\varnothing$ 1.1

## Series PT

Suitable for TRAFIMET®  
S25 - S25 K  
S30 - S35 K  
S45

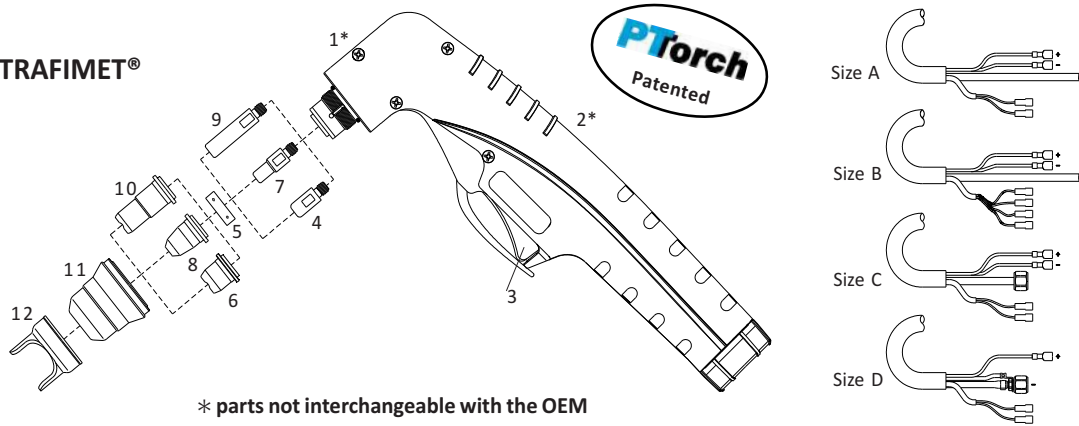

\* parts not interchangeable with the OEM

No.	Ref.	Code	Description	No.	Ref.	Code	Description
	PA0370	09622	Hand torch PT-20C, 4m, size B		PD0116-08	51316	Tip $\varnothing$ 0.8
	PA0375	09623	Hand torch PT-20C, 4m, size A		PD0116-09	51316.09	Tip $\varnothing$ 0.9
	PA0376	09620	Hand torch PT-20C, 4m, size A	9	PR0106	52532	Extended electrode
	PA0167	09632	Hand torch PT-40, 4m, 1/4G, size C	10	PD0103-65	51317.06	Extended tip $\varnothing$ 0.65
	PA0165	09634	Hand torch PT-40, 6m, 1/4G, size D		PD0103-09	51317.09	Extended tip $\varnothing$ 0.9
	PA0166	09635	Hand torch PT-40, 6m, central conn.		PD0103-10	51317	Extended tip $\varnothing$ 1.0
1*		09600	Torch head PT-20C	11	PC116	60389	Retaining cap
		09602	Torch head PT-40		PC122	60389K1	Retaining cap (1 hole)
2*		09605	Handle with Switch		PC117	60389K	Retaining cap (2 holes)
3	BX0020	07301.20	Switch			60389K4	Retaining cap (4 holes)
4	PR0105	52536	Electrode	12		60431	Double Pointed Spacer
5	PE0106	60028	Swirl ring	*		09682	Cable 4m, PT-20C, size B
6	PD0102-09	51315.09	Tip $\varnothing$ 0.9	*		09680	Cable 4m, PT-20C, size A
	PD0102-10	51315	Tip $\varnothing$ 1.0	*		09687	Cable 4m, PT-40, 1/4G, size C
7	PR0110	52531	Electrode	*		09688	Cable 6m, PT-40, 1/4G, size D
8	PD0116-06	51316.06	Tip $\varnothing$ 0.65	*		09689	Cable 6m, PT-40, cent. conn.

## TRAFIMET® A80-P80®

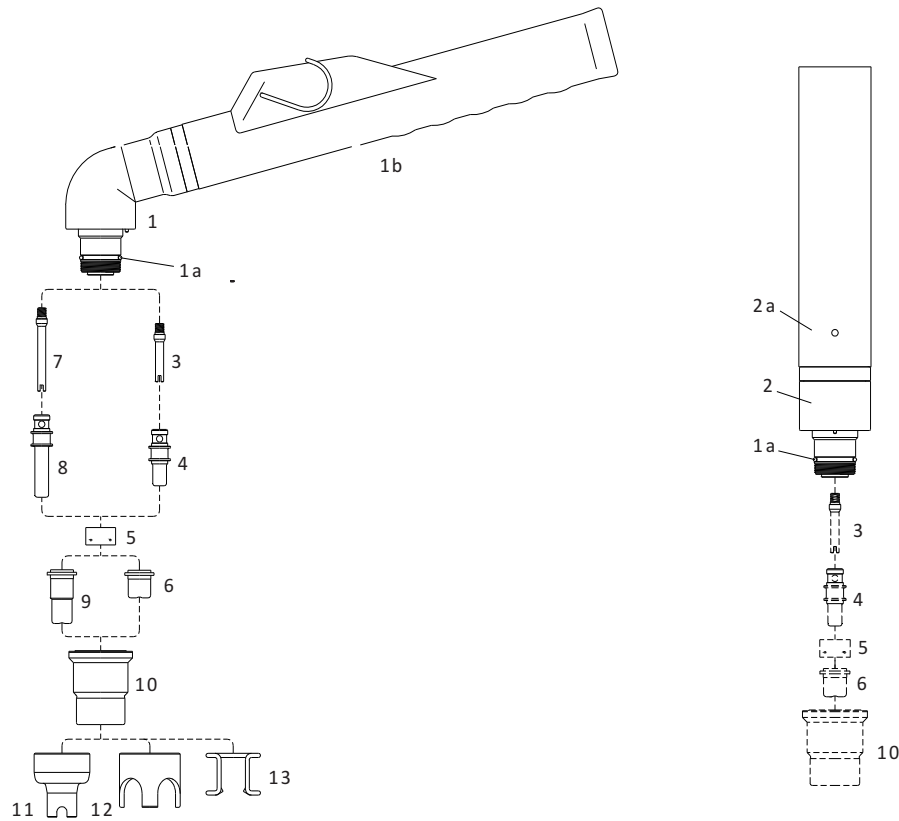

No.	Ref.	Code	Description	No.	Ref.	Code	Description
	PA170	06820	Hand torch 6m 3/8 G - 1/4 G	6	PD105-11	51172	Tip $\varnothing$ 1.1
	PA1402	06821	Hand torch 6m cent. connector		PD105-12	51172.12	Tip $\varnothing$ 1.2
	PA180	06840	Machine torch 6m 3/8 G	7	FH0561	06801.43	Extended diffusor
	PA181	06841	Machine torch 6m cent. connector	8	PR115	52581/S	Extended electrode
1	PF119	06800	Hand torch head	9	PD106-10	51171.10	Extended tip $\varnothing$ 1.0
1a	EA125	07300.60	O-Ring		PD106-12	51173	Extended tip $\varnothing$ 1.2
1b		04280/C	Handgrip with microswitch	10	PC115	60384	Retaining cap
2	PF120	06811	Machine torch head	11	CV201	51976	Spacer for contact cutting
2a	TP61	06815	Machine handle	12	CV33	60378	Crown spacer
3	FH0560	06801.42	Diffusor	13	CV28	51902	Spacer spring
4	PR109	52580/S	Electrode		PH130/132	06880	Cable 6m 3/8G - 1/4G
5	PE107	60029	Swirl ring				Hand/Machine torch
6	PD105-10	51170	Tip $\varnothing$ 1.0		PF107	06800/KIT	Kit for replacing "A60"

## LT-81®

Suitable for **ERGOCUT® A81®**  
**TRAFIMET® A80®**

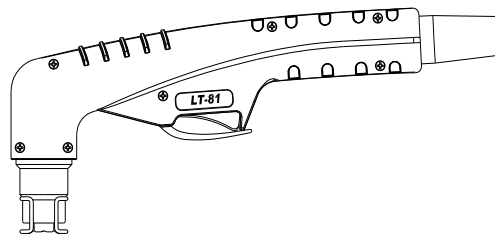

Consumables:  
see **A80-A81®**

Ref.	Code	Description	Ref.	Code	Description
PA170/1400/1404	06820LT	Hand torch, 6m, 3/8G connection	EA0125	07300.60	O-Ring
PA1402	06821LT	Hand torch, 6m, central connector		09706	Handgrip with switch
PF0140	06802/KIT	Torch head with handle	BX0020	07301.20	Switch
	06802	Torch head			

## TRAFIMET® A90-P90®

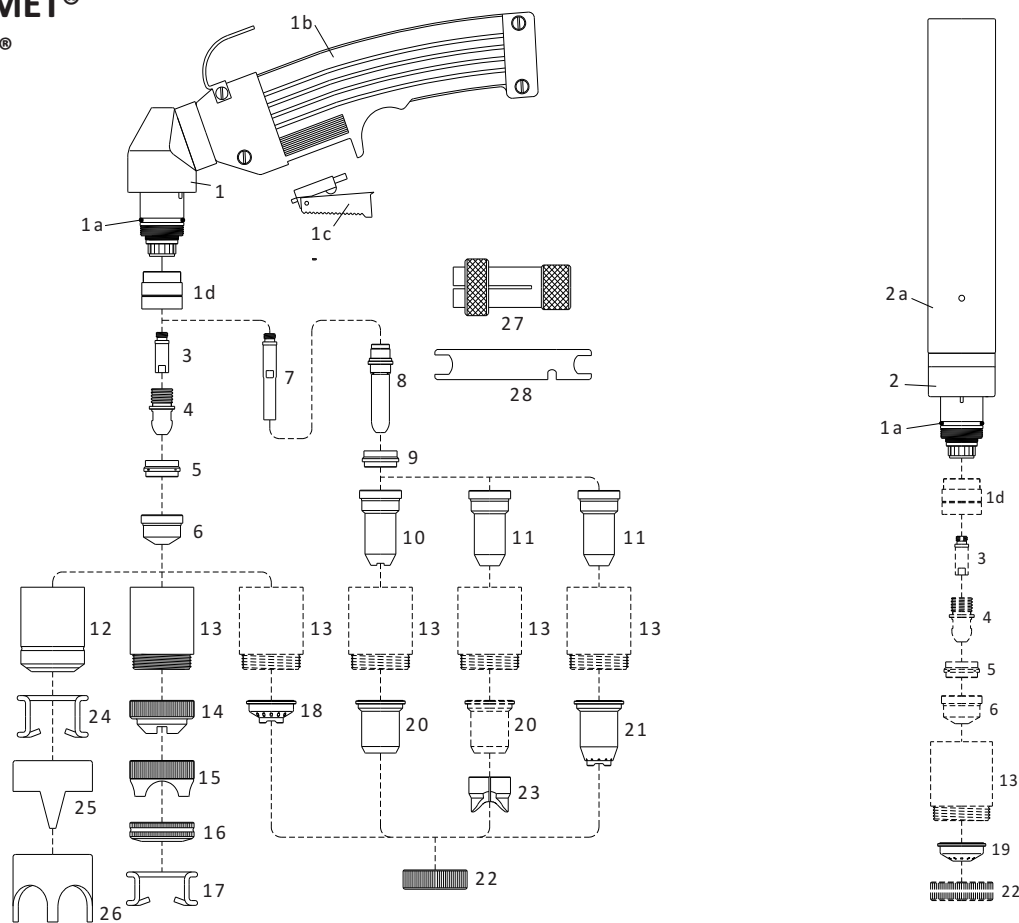

No.	Ref.	Code	Description	No.	Ref.	Code	Description
	PA109	06050	Hand torch 6m M14x1	11	PD117-14	51149.14	Extended tip $\varnothing$ 1.4
		06051	Hand torch 6m central connector		PD117-17	51149.17	Extended tip $\varnothing$ 1.7
	PA209	06150	Hand torch 12m M14x1	12	PC109/111	60376	Retaining cap, long life
		06151	Hand torch 12m (central connector)	13	PC113/130	60386	Contact retaining cap
	PA110	06650	Machine torch 6m M14x1		PC113/130	60386/V	Contact retaining cap, Max.life
	PA111	06651	Machine torch 6m central connector	14	CV23	51940	Spacer for contact cutting
		06750	Machine torch 12m M14x1	15	CV39	51945	Large spacer for contact cutting
		06751	Machine torch 12m central connector	16		51952	Spring holder protection nut
1	PF109	06000	Hand torch head	17		51911	Spacer spring for code 51952
1a	EA131	06000.60	O-Ring	18		51950	Spacer for contact cutting, hand
1b		07301	Handgrip complete with switch	19		51951	Shield cup, machine
1c		07301.20	Switch	20	CV8	51957	Shield cup, hand max. 50A
1d		60085	Front insulator	21	CV9	51958	Spacer for contact cutting, hand
2	PF115	06600	Machine torch head	22		51959	Locking nut
2a		03310	Machine handle	23		51974	Spacer for extended tips High Amp.
3		06004	Diffusor	24	CV11	51910	Spacer spring
4	PR101	52535	Electrode	25	CV12	60370	Double pointed spacer
5	PE101	60030	Swirl ring	26	CV14	60371	Crown spacer
6	PD101-11	51154	Tip $\varnothing$ 1.1	27	GR60	60369	Extractor for swirl ring
	PD101-14	51155	Tip $\varnothing$ 1.4	28		60368	Wrench for electrode
	PD101-17	51156	Tip $\varnothing$ 1.7				
7		06005	Extended Diffusor			04224	Cable 6m M14x1 - Hand torch
8	PR116	52530	Extended electrode			04234	Cable 12m M14x1 - Hand torch
9	PE103	60031	Insulating spacer			04222	Cable 6m M14x1 - Machine torch
10	PD111	51149	Extended tip $\varnothing$ 1.1 ( max. 50A )			04232	Cable 12m M14x1 - Machine torch

## TRAFIMET® A140-P140®

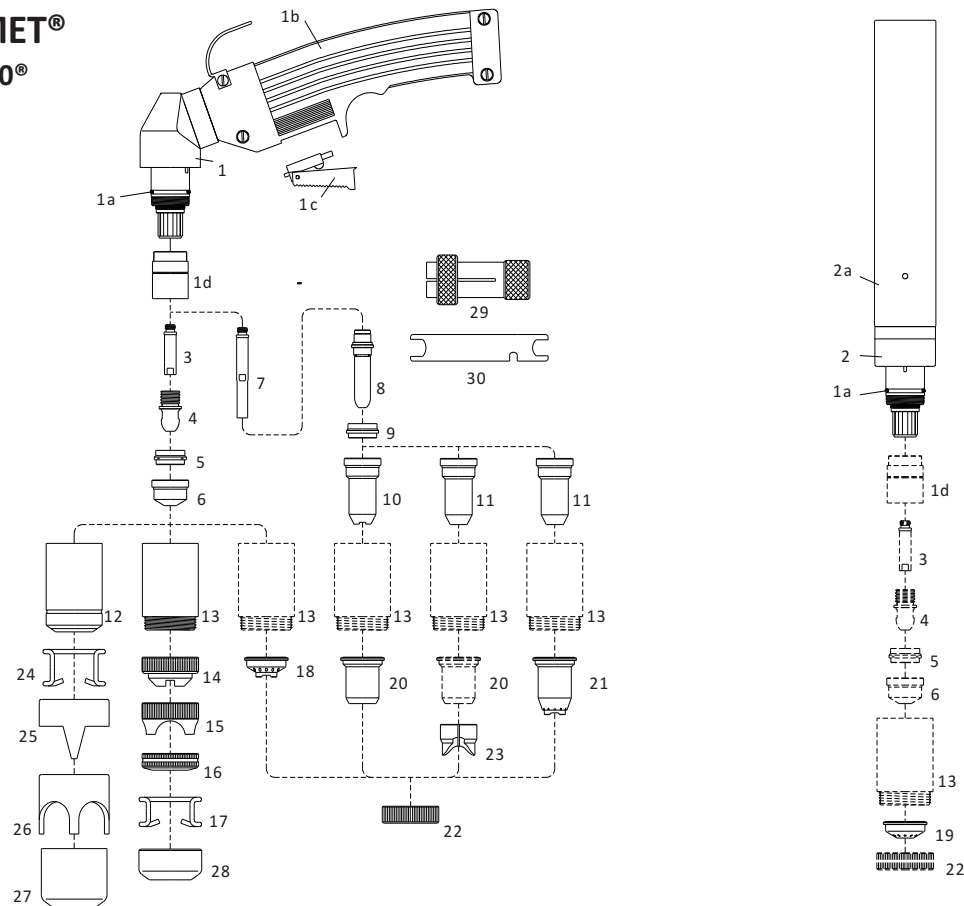

No.	Ref.	Code	Description	No.	Ref.	Code	Description
	PA101	06250	Hand torch 6m M14 x 1	11	PD117-14	51149.14	Extended tip $\varnothing$ 1.4
		06251	Hand torch 6m cent. connector			51149.17	Extended tip $\varnothing$ 1.7
	PA102	06350	Hand torch 12m M14 x 1			51149.19	Extended tip $\varnothing$ 1.9
		06351	Hand torch 12m cent. connector	12	PC101/102	60375	Retaining cap, long life
	PA103	06450	Machine torch 6m M14 x 1	13	PC103/131	60385	Contact retaining cap
	PA145	06451	Machine torch 6m cent. connector		PC103/131	60385/V	Contact retaining cap, Max.life
	PA104	06550	Machine torch 12m M14 x 1	14	CV23	51940	Spacer for contact cutting
	PA146	06551	Machine torch 12m cent.conn.	15	CV39	51945	Large spacer for contact cutting
1	PF101	06200	Hand torch head	16		51952	Spring holder protection nut
1a	EA131	06000.60	O - Ring	17		51911	Spacer spring for code 51952
1b		07301	Handgrip complete with switch	18		51950	Spacer for contact cutting, hand
1c		07301.20	Switch	19		51951	Shield cup, machine
1d		60080	Front insulator	20	CV8	51957	Shield cup, hand (max. 50A)
2	PF102	06400	Machine torch head	21	CV9	51958	Spacer for contact cutting, hand
2a		03310	Machine handle	22		51959	Locking nut
3		05004	Diffusor	23		51974	Spacer for extended tips High Amp.
4	PR101	52535	Electrode	24	CV11	51910	Spacer spring
5	PE101	60030	Swirl ring	25	CV12	60370	Double pointed spacer
6	PD101 - 11	51154	Tip $\varnothing$ 1.1	26	CV14	60371	Crown spacer
	PD101 - 14	51155	Tip $\varnothing$ 1.4	27	CV13	60373	Gouging spacer
	PD101 - 17	51156	Tip $\varnothing$ 1.7	28		51953	Gouging spacer
	PD101 - 19	51157	Tip $\varnothing$ 1.9	29	GR60	60369	Extractor for swirl ring
	PD101 - 30	51158	Gouging tip $\varnothing$ 3.0	30		60368	Wrench for electrode
7		05005	Extended Diffusor			04220	Cable 6m M14 x 1 - Hand torch
8	PR116	52530	Extended electrode			04230	Cable 12m M14 x 1 - Hand torch
9	PE103	60031	Insulating spacer			04222	Cable 6m M14 x 1 - Machine torch
10	PD111	51149	Extended tip $\varnothing$ 1.1 (max. 50A)			04232	Cable 12m M14 x 1 - Machine torch

## TRAFIMET® R145-R145P®

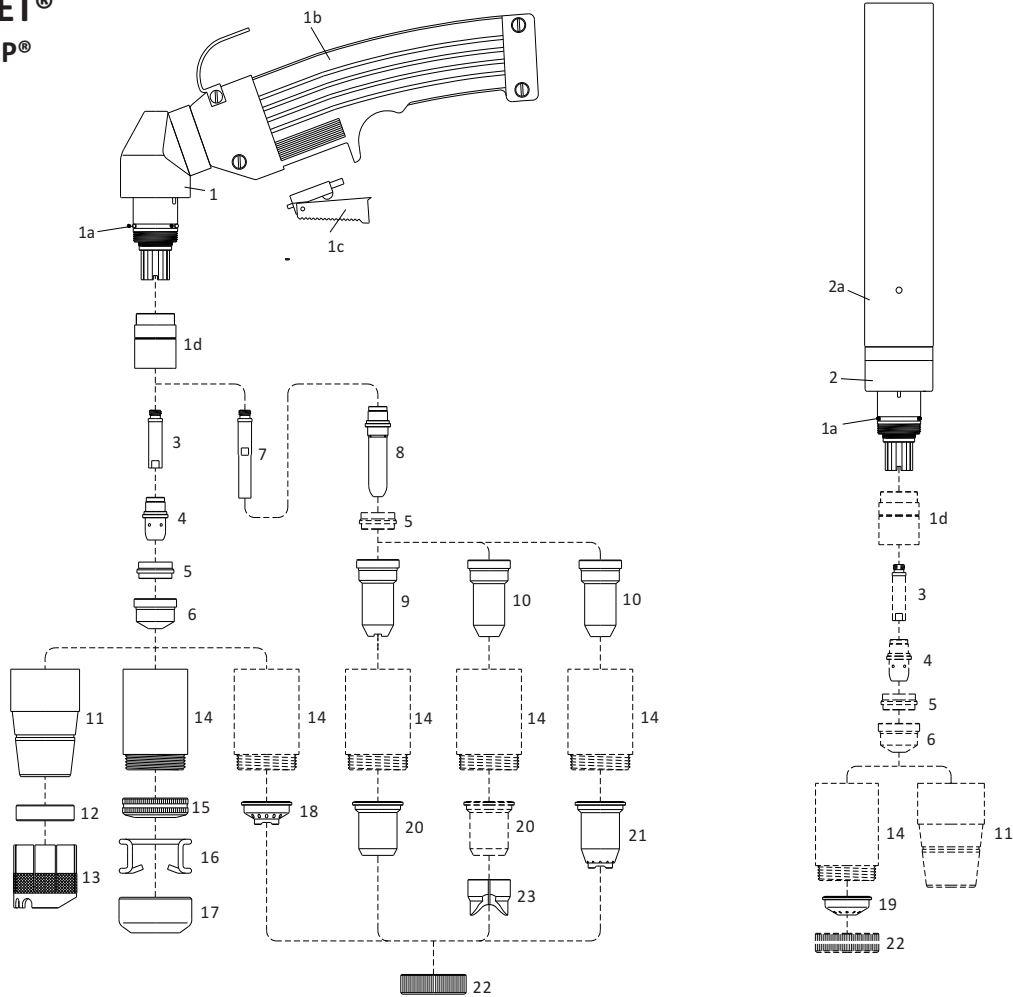

No.	Ref.	Code	Description	No.	Ref.	Code	Description
PA129		06920/S	Hand torch 6m M14 x 1	8	PR116	52530	Extended electrode
		06921/S	Hand torch 6m cent. connector	9	PD111	51149	Extended tip $\varnothing$ 1.1 ( max 50A )
PA130		06930/S	Hand torch 12m M14 x 1	10	PD117-14	51149.14	Extended tip $\varnothing$ 1.4
		06931/S	Hand torch 12m cent. conn.		PD117-17	51149.17	Extended tip $\varnothing$ 1.7
PA127		06940/S	Machine torch 6m M14 x 1		PD117-19	51149.19	Extended tip $\varnothing$ 1.9
PA252		06941/S	Machine torch 6m cent. conn.	11	PC120	60387	Retaining cap
PA128		06950/S	Machine torch 12m M14 x 1	12	BW139	60388	Nozzle shield
PA253		06951/S	Machine torch 12m cent. conn.	13	CV1105	60379	Cage spacer
1	PF112	06900	Hand torch head	14	PC103/131	60385	Contact retaining cap
1a	EA131	06000.60	O - Ring		PC103/131	60385/V	Contact retaining cap, Max.life
1b		07301	Handgrip complete with switch	15		51952	Spring holder protection nut
1c		07301.20	Switch	16		51911	Spacer spring for code 51952
1d		60080	Front insulator	17		51953	Gouging spacer
2	PF111	06910	Machine torch head	18		51950	Spacer for contact cutting, hand
2a		03310	Machine handle	19		51951	Shield cup, machine
3		05004	Diffusor	20	CV8	51957	Shield cup, hand (max. 50A )
4	PR111	52534	Electrode	21	CV9	51958	Spacer for contact cutting, hand
5	PE103	60031	Insulating spacer	22		51959	Locking nut
6	PD109-14	51241	Tip $\varnothing$ 1.4	23		51974	Spacer for extended tips High Amp.
	PD109-16	51242	Tip $\varnothing$ 1.6			04220/S	Cable 6m (M14x1) - Hand torch
	PD109-18	51243	Tip $\varnothing$ 1.8			04230/S	Cable 12m (M14x1) - Hand torch
	PD109-30	51244	Gouging tip $\varnothing$ 3.0			04222/S	Cable 6m (M14x1) - Machine torch
7		05005	Extended Diffusor			04232/S	Cable 12m (M14x1) - Machine torch

## LT-101®

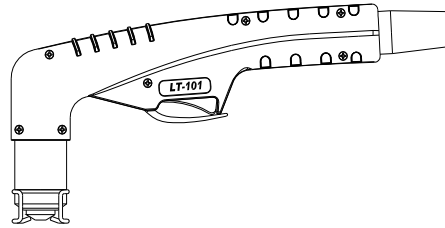

Suitable for **ERGO-CUT® A101®**  
**TRAFIMET® A90®**

Consumables:  
see **A90-A101®**

Ref.	Code	Description	Ref.	Code	Description
PA109/1450/1454	06050LT	Hand torch, 6m, M14x1		06001	Torch head
PA1452	06051LT	Hand torch, 6m, central connector	EA0131	06000.60	O-Ring
PA209	06150LT	Hand torch, 12m, M14x1		09706	Handgrip with switch
	06151LT	Hand torch, 12m, central connector	BX0020	07301.20	Switch
PF0145	06001/Kit	Torch head with handle			

## LT-141®

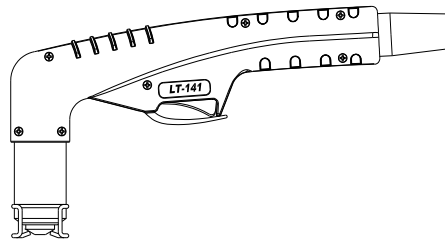

Suitable for **ERGO-CUT® A141®**  
**TRAFIMET® A140®**

Consumables:  
see **A140-A141®**

Ref.	Code	Description	Ref.	Code	Description
PA101/1500/1502	06250LT	Hand torch, 6m, M14x1		06201	Torch head
PA1504	06251LT	Hand torch, 6m, central connector	EA0131	06000.60	O-Ring
PA102/1501	06350LT	Hand torch, 12m, M14x1		09706	Handgrip with switch
PA1505	06351LT	Hand torch, 12m, central connector	BX0020	07301.20	Switch
PF0155	06201/Kit	Torch head with handle			

## LT-151®

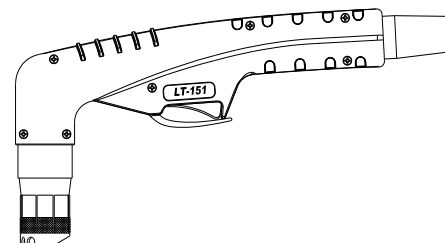

Suitable for **ERGO-CUT® A151®**  
**TRAFIMET® R145®**

Consumables:  
see **R145-A151®**

Ref.	Code	Description	Ref.	Code	Description
PA129/1550/1552	06920LTS	Hand torch, 6m, M14x1		06901	Torch head
PA1554	06921LTS	Hand torch, 6m, central connector	EA0131	06000.60	O-Ring
PA130/1551	06930LTS	Hand torch, 12m, M14x1		09706	Handgrip with switch
PA1555	06931LTS	Hand torch, 12m, central connector	BX0020	07301.20	Switch
PF0160	06901/Kit	Torch head with handle			